



# CIRTEK ELECTRONICS CORPORATION

116 East Avenue, Phase V, SEZ Laguna Technopark  
Biñan, Laguna, Philippines

## PRODUCT INFORMATION

Customer :

Device :

Die Size :

Package Type :

Device ID :

Wafer Material :

No. of Wires :

16L SOIC NB

## MATERIAL INFORMATION

Leadframe : A194 with spot Ag

Epoxy :

Molding Compound :

Pad Size : 90 X 110 mils

Gold Wire :

Lead Finish :

## MARKING INSTRUCTION

TOP :

BOTTOM :

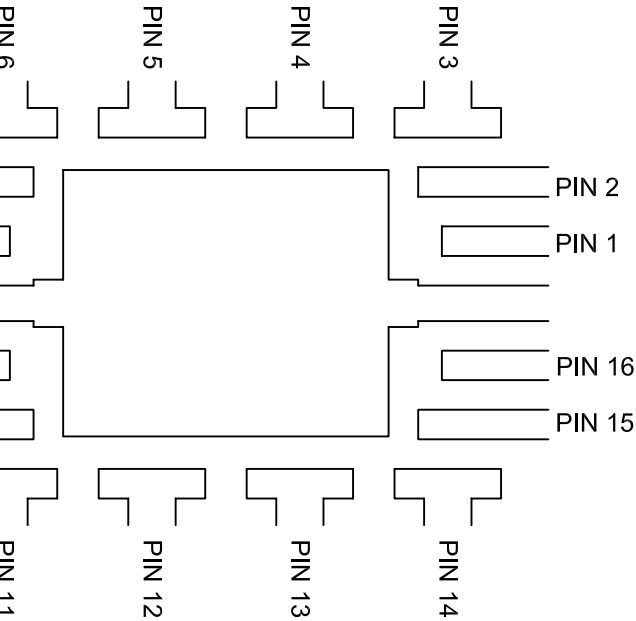

BONDING DIAGRAM NO.

REF. BONDING DIAGRAM NO.

SCALE

not to scale

DRAWN BY :

REVIEWED BY :

Note:

### REVISION NO.

### APPROVALS

REV. #	DESCRIPTION	ECN #	DEPT	APPROVALS	DATE
			CUST		
			QSM		
			QC		
			MFG		